



润圣
RUNSHENG

RL密集型母线槽系统

RL-INTENSIVE BUSWAY SYSTEM

江苏润圣电气有限公司

Jiangsu Runsheng Electric Co., Ltd.

关于我們

江苏润圣电气有限公司位于著名的国家级生态岛、国家级工程电气产业岛——扬中市，润圣电气经过 10 年的快速发展，一跃成为扬中市规模骨干企业，先后被授予江苏省重合同守信用企业、江苏省民营科技企业、江苏省科技型中小企业等荣誉称号，公司产品荣获江苏省、镇江市知名商标。

润圣电气是一家科技型工程电气制造企业，公司位于扬中市城北科技园内，占地面积 20000 平方米，公司拥有先进的数控剪、折、冲等生产设备以及齐全的检测手段，拥有员工 121 人，其中拥有大专以上学历的员工 85 余人，为企业科学发展提供了坚实基础和人才支撑。润圣电气始终坚持科技创新为引领，以打造行业标准为追求，致力科技产品领先行业、普通产品行业最精。目前公司主要产品有：高压固封式真空断路器；高、低压成套开关柜；高压封闭母线；智能型母线槽；配电网母线在线监测系统；电缆桥架等，共有七大系列 1000 多个品种，广泛应用于电网、电力、冶金、建材、石化、机械、城市建设、交通、水利、煤炭等行业。

润圣电气自创办以来，坚持以科技求领先、以质量求生存、以服务求发展，重合同、守信用，热忱为广大客户提供质量上乘、标准规范的电力电气产品。公司严格按照 ISO9001 质量管理体系规范设计、开发、生产、服务全过程，并于 2003 年通过中国方圆认证委员会 ISO9001 质量管理体系认证，于 2009 年通过中国方圆认证委员会 ISO14001 环境管理体系认证、OHSAS18001 职业健康安全管理体系认证。生产的高压固封式真空断路器、高压开关柜、高压封闭母线通过了国家权威检测机构——国家高压电器监督检验中心的全套型式试验，低压配电柜、母线槽通过国家强制性认证（3C 认证）。应市场需求，企业新开发的 3AR-EP/T4000-40/T1600-31.5 系列固封式真空断路器、RKYN28-12/T4000-40 型金属铠装移开式开关设备通过省级科技成果鉴定，达到国际先进水平。

“制造标准，成就品牌”是润圣人的执着追求，“卓越质量，诚信服务”是润圣人的经营宗旨，润圣人本着“做精品、做标准、做领先”的发展理念，进一步加快企业产品高端化、标准示范化、品牌知名步伐，不断将企业产品标准演变为行业标准，成为具有高度竞争力和领先优势的规模制造企业，使润圣电气成为电力电气行业中具有自主知识产权和知名品牌的领军企业。

江苏润圣电气有限公司

About Us

Jiangsu RunSheng Electrical Co., Ltd. is located in the famous national ecological Island and National Engineering Electrical Industry Island - Yangzhong City. RunSheng Electric, after 10 years of rapid development, has become backbone enterprises in Yangzhong. The company has been awarded "trustworthy enterprise", "private technological enterprise" and other honorary titles, and the company's products have won the honor of "well-known trademarks" in Jiangsu Province and Zhenjiang City.

RunSheng Electric is a science and technology based electrical manufacturing enterprise. The company is located in the Yangzhong North Industrial Park, covering an area of 20,000 square meters. The company has advanced CNC cutting, bending, punching machines, and other production equipment and complete measures of inspection and testing. We have 121 employees, including over 85 employees with a college education, which provides a solid foundation and personnel support for the development of the scientific enterprise. RunSheng Electric always adheres to scientific and technological innovation as well as industrial standards for the pursuit of quality and standard products. Company's main products: high-voltage solid sealing vacuum circuit breaker; high-voltage and low-voltage switchgear; high-voltage enclosed busbar trunking units; Intelligent busbar trunking units; on-line monitoring system for power distribution busway; cable tray, consisting of seven series with more than 1,000 varieties. These products are widely used in the power grid, power distribution, metallurgy, building materials, petrochemical, machinery, urban construction, transportation, water conservancy, coal and other industries.

RunSheng Electric, since the inception, targets for the science and technology advantage, adheres to quality and service orientation, keeps good credit and provides our customers with quality and standard power electrical products. The company, in strict accordance with the ISO9001 quality management system specifications, designs, develops, produces, and serves. The company in 2003 got the certification of ISO 9001 quality management system by CQM, in 2009 the ISO14001 environmental management system certification, OHSAS18001 occupational health safety management system certification by CQM. The high-voltage solid sealing vacuum circuit breakers, high voltage switchgear, high voltage enclosed busbar trunking units passed complete type tests by the national authoritative testing organizations - national high-voltage electrical Supervision and Inspection Center; low voltage power distribution cabinet, busbar trunking units got China Compulsory Certification (3C certification). In response to market demand, the company has newly developed 3AR-EP/T4000- 40/T1600- 31.5 Series solid sealing vacuum circuit breaker, RKYN28 12/T4000- 40 type metal armored movable switchgear, which have been appraised as "provincial science and technology achievement" reaching the international advanced level.

Standard Products and Famous Brand is our pursuit; Excellent Quality and Trustworthy Service is our management philosophy; with the goal of "Quality, Standard, Advantage", the enterprise further quickens the pace towards high-end products, standard model, brand recognition, and constantly promotes enterprise products standard for industrial standard, to become highly competitive manufacturing enterprise with leading-edge, and the leading enterprise in electrical power industry with independent intellectual property rights and well-known brand.

www.run-sheng.cn

→ 目录 CONTENTS

● 系统部件 System Parts	01
● 技术参数 Technical Specifications	04
● 产品编码 Product Coding	06
● 系统配置 System Configuration	08
● 功能单元 Functional Unit	11
● 加工设备 Processing Equipment	20
● 计算及选型 Calculation and Selection	21
● 安装规范 Busbar Trunking System Installation	25
● 维修与保养 Repair and maintenance	28
● 资质文件 Certificates	29
● 订货须知 Ordering Information	35

【 系统概述 】 System overview

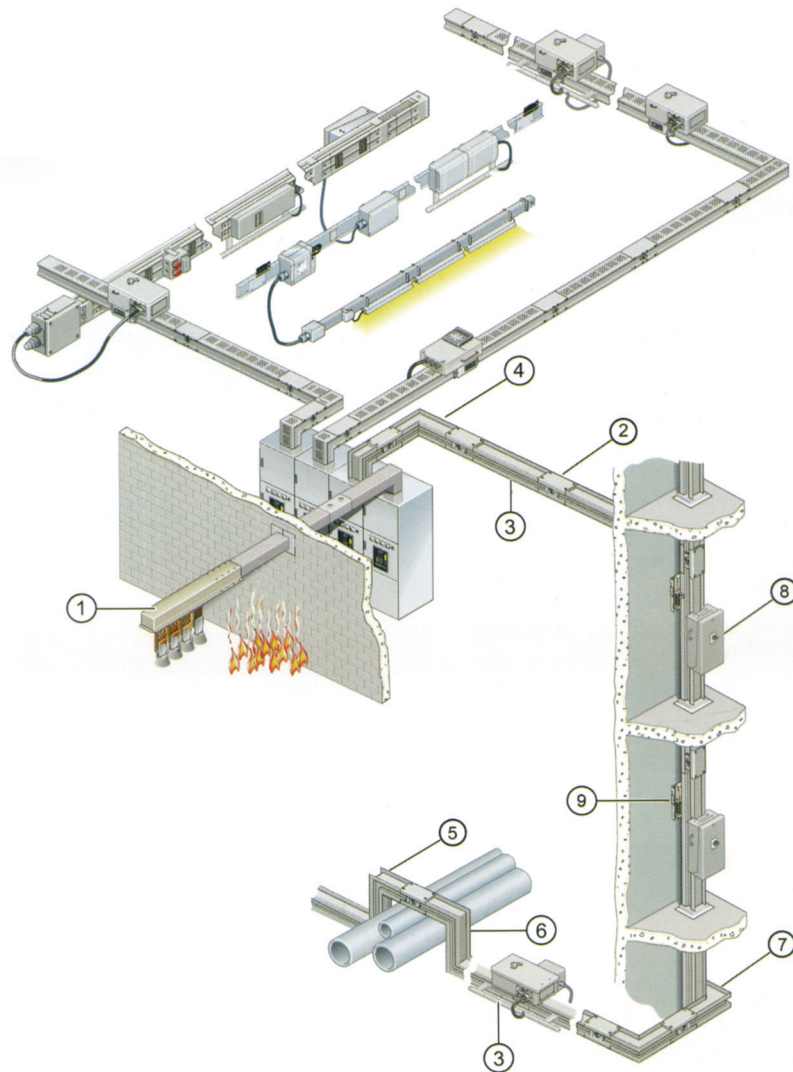

- 1、变压器连接单元 Transformer Connection Unit
- 2、连接器 Joint
- 3、直接线段母线 Straight Busduct
- 4、水平弯头 Horizontal Elbow
- 5、垂直弯头 Vertical Elbow
- 6、Z型垂直弯头 Z Type Edgewise Elbow
- 7、异型弯头 Nonstandard Elbow
- 8、插接箱 Tap-off Unit
- 9、弹性支撑器 Spring Hanger

【系统部件基本描述】 System components overview

02

密集型母线槽是一种灵活可靠的配电系统，设计合理、性能优越、具有稳定可靠、配电效能高等特点。密集型母线槽设计有RL铜母线系统及RLA铝母线系统，防护等级最高可达IP65，能在各种恶劣环境下安全运行，插接箱最大容量可达1250A，可满足不同用户对输、配电需求。

Intensive Busway is a flexible and reliable power distribution system, with reasonable design, excellent performance, stable and reliable distribution and high performance. Intensive busbar trunking units are designed with RL copper busbar and RLA aluminum busbar system, with protection class up to IP65, which can be applied safely in a variety of harsh environments. The maximum capacity of tap-off box is up to 1250A, meeting the different requirements of users for the power transmission and distribution.

1 直线段单元 Straight trunking units

根据用户要求可以加装穿墙套管单元，防护等级IP54，
(防护等级最高可达IP65)

Wall Bushing Unit can be installed according to user's requirement.
Protection class IP54,
(Protection class up to IP65)

馈电式和插接式

Feeder and Tap-off

标准长度

Standard length

RL: 1m/2m/3m/4m/6m

RL: 1m/2m/3m/4m/6m

RLA: 1m/2m/3m/4m/6m

RLA: 1m/2m/3m/4m/6m

可选长度

Optional length

RL: 0.5~5.99m

RL: 0.5 ~ 5.99m

RLA: 0.5~5.99m

RLA: 0.5 ~ 5.99m

安装方式垂直安装及水平安装

Installation Type: Vertical and Horizontal

插接母线

With tap-off points Straight trunking units

单面设插口

Single socket set

双面设插口

Sided socket set

可根据客户需求预留插口

Jack can be reserved according to customer demand

插口防护等级为IP54

Jack protection class IP54

能有效防止错位安装

Misaligned installation can be effectively prevented.

2 插接箱单元 Tap-off units

采用断路器或熔断器保护

Using a circuit breaker or fuse protection

钢制外壳

Steel shell

良好的接地

Good grounding

防护等级IP54

Protection class IP54

安装方便

Easy installation

机械联锁装置

Mechanical interlock

能有效防止错位安装

Installation can effectively prevent misalignment

插脚镀银处理

Silver plated pin handle

3 进线单元 Feeder units

变压器进线单元

配置有专用的软连接装置
最大额定电流可达6300A

Transformers incoming unit

Configure a dedicated soft connection
Maximum rated current up to 6300A

低压柜进线单元

配置有专用的硬连接（连接铜排）装置
最大额定电流可达6300A

Low-voltage cabinet incoming unit

Configure a dedicated hard links (connecting copper) devices
Maximum rated current up to 6300A

03

4 智能连接装置 Intelligent connection device

- 接头器绝缘材料采用DMC复合型高效绝缘模塑料高温模压，具有很高的抗压性、耐弧阻燃性和综合电抗性能；
- 宽沿蝶形弹簧，确保了接触面受力均匀，并防止松动；
- 双头螺栓设计，安装时仅需一把普通19#扳手拧断外部螺母即可保证安装力矩（80N·M）。

- The insulation materials of connector is efficient DMC composite insulating material, using high temperature compression molding, which has high compression resistance, arc resistance flame resistant as well as integrated reactance properties;
- Wide-brim butterfly spring ensures the contact surface under uniform force and prevents its loosening;
- With stud design, only an ordinary 19 # wrench is need for installation to break off the external nut, which ensures the mounting torque (80N·M).

5 换向单元 Angle and branch units

方便的更改一段母线槽的走向
角度为70~175度

L型单元

T型单元

Z型单元

Easy to change the direction of busbar trucking
Angle of 70 degrees to 175

L-type unit

T-cell

Z-type unit

6 附件 Attachment

终端封头

连接器

垂直/水平安装支架

连接材料

End caps

Joint block

Vertical / horizontal mounting bracket

Connecting material

系统通用技术参数 Technical Data

04

符合标准 Standards compliant	IEC60439-1、GB7251-1、2
Min./Max./24小时平均温度 Min./Max./24 hour average temperature	-25/+40/35°C
防护等级 Protection class	IP54、IP65
连接力矩 Connection torque	80 N·M
表面处理 Surface treatment	静电粉末喷涂（根据客户需求） Electrostatic powder coating (according to customer needs)
外壳材料 Case Material	铝镁合金 Aluminum-magnesium alloy
外壳颜色 Shell color	国际标准灰（RAL7032、RAL7035），具体颜色按客户需求 International standard gray (RAL7032, RAL7035), specific colors according to customer needs
额定绝缘电压 U_i Rated insulation voltage U_i	690VAC
额定工作电压 U_e Rated operating voltage U_e	400VAC
额定频率 f Rated frequency f	50/60HZ
额定电流 I_e Rated current I_e	见RL/RLA技术参数表
额定短时耐受电流 I_{cw} Rated short-time withstand current I_{cw}	见RL/RLA技术参数表
额定峰值耐受电流 I_{pk} Rated peak withstand current I_{pk}	见RL/RLA技术参数表
导体材料 Conductor material	Cu、Al
最大安装距离 Maximum mounting distance	3m
外形尺寸 Dimensions	见母线槽外形尺寸

注：1）选择不同的电流等级，相对应不同的数据；
2）详细的数据可以参照下一节技术参数表。

Note: 1) Select a different current levels, corresponding to different data;
2) detailed data can refer to the next section Technical Data Sheet.

RL技术参数表 (铜母线系统) RL Technical Data (Copper Busbar System)

电流 (A)	短时耐 受电流 (I _{cw})KA	峰值耐 受电流 (I _{pk})KA	电阻/米 (mΩ)	电抗/米 (mΩ)	阻抗/米 (mΩ)	每米压降 (V)	外形尺寸	
			10 ⁻⁶ Ω/m				宽度	高度
400	30	63	133	37.1	139	0.061	145	102
630			85	26.5	89	0.061	145	102
800			76	24	79.6	0.055	145	102
1000	50	105	63.1	21	66.4	0.058	145	112
1250			51	17	53.5	0.058	145	127
1600	80	176	37.4	12.6	39.5	0.068	145	157
2000			31.1	10.4	32.7	0.071	145	182
2500			23.9	7.89	25.1	0.067	145	227
3000			20.7	6.82	21.8	0.071	145	257
3200			17.1	5.58	18	0.063	145	307
4000	100	220	12.6	4.16	13.3	0.058	145	415
5000			10.3	3.41	10.9	0.06	145	495
6300			8.54	2.79	89.8	0.062	145	595

05

RLA技术参数表 (铝母线系统) RLA Technical Data (Aluminum Busbar System)

电流 (A)	短时耐 受电流 (I _{cw})KA	峰值耐 受电流 (I _{pk})KA	电阻/米 (mΩ)	电抗/米 (mΩ)	阻抗/米 (mΩ)	每米压降 (V)	外形尺寸	
			10 ⁻⁶ Ω/m				宽度	高度
400	30	63	124	24.2	127	0.057	145	102
630			103	20.7	105	0.074	145	112
800			83.1	17	84.8	0.076	145	127
1000	50	105	61.2	12.6	62.5	0.07	145	157
1250			50.8	10.4	51.9	0.073	145	182
1600			41.3	8.32	42.1	0.076	145	227
2000			33.9	6.82	34.6	0.077	145	257
2500	80	176	28	5.56	28.5	0.08	145	307
3200			16.9	3.41	17.3	0.062	145	495
4000			14	2.79	14.3	0.064	145	595

密集型母线槽编码系统 Intensive Busbar Trunking Coding System

06

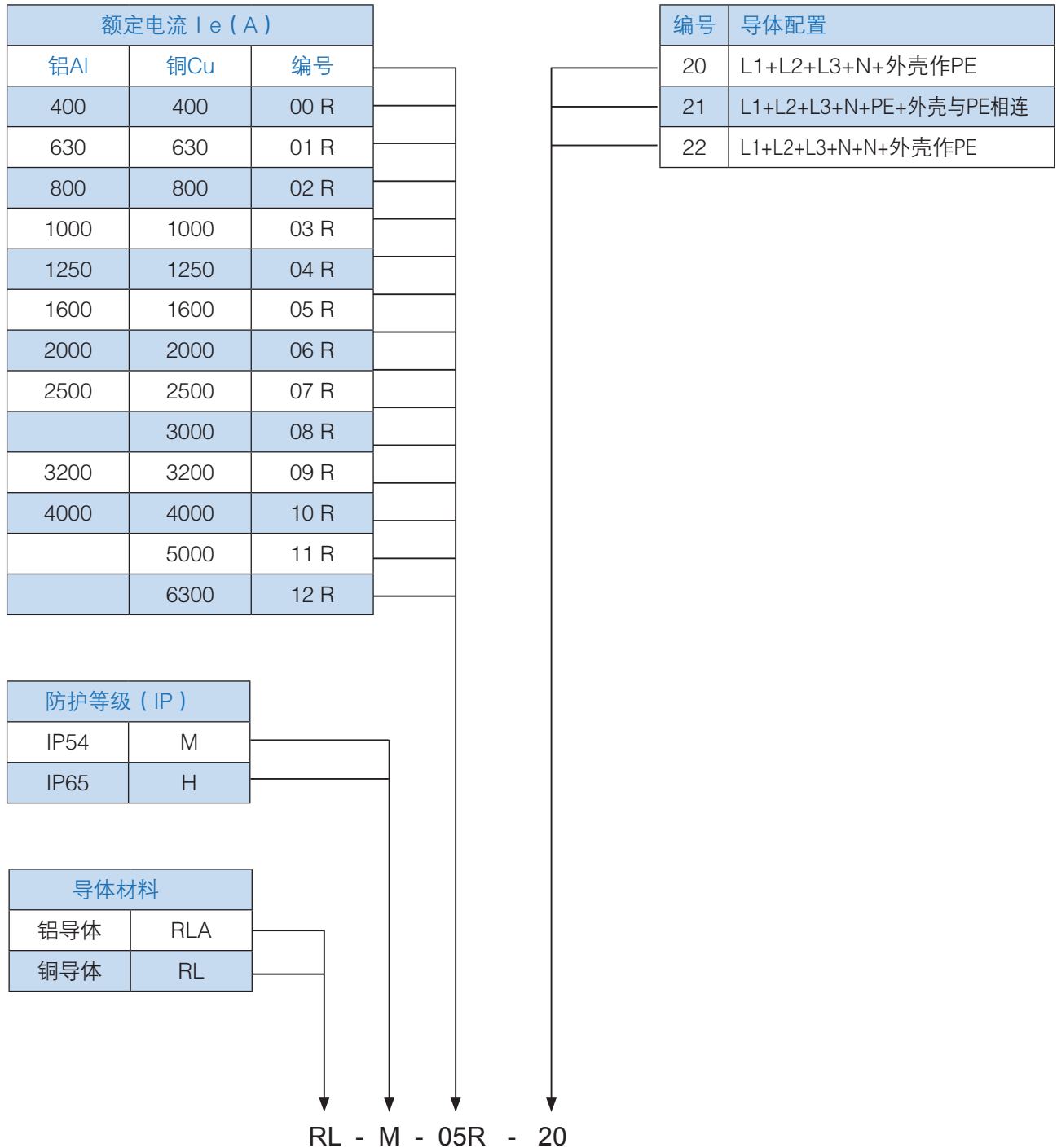

选型案例：项目额定电流1600A，应用铜母线系统五线制，外壳为PE，防护等级为IP54系统代码为：RL-M-05R-20

插接箱编码系统 Tap-off Units Coding System

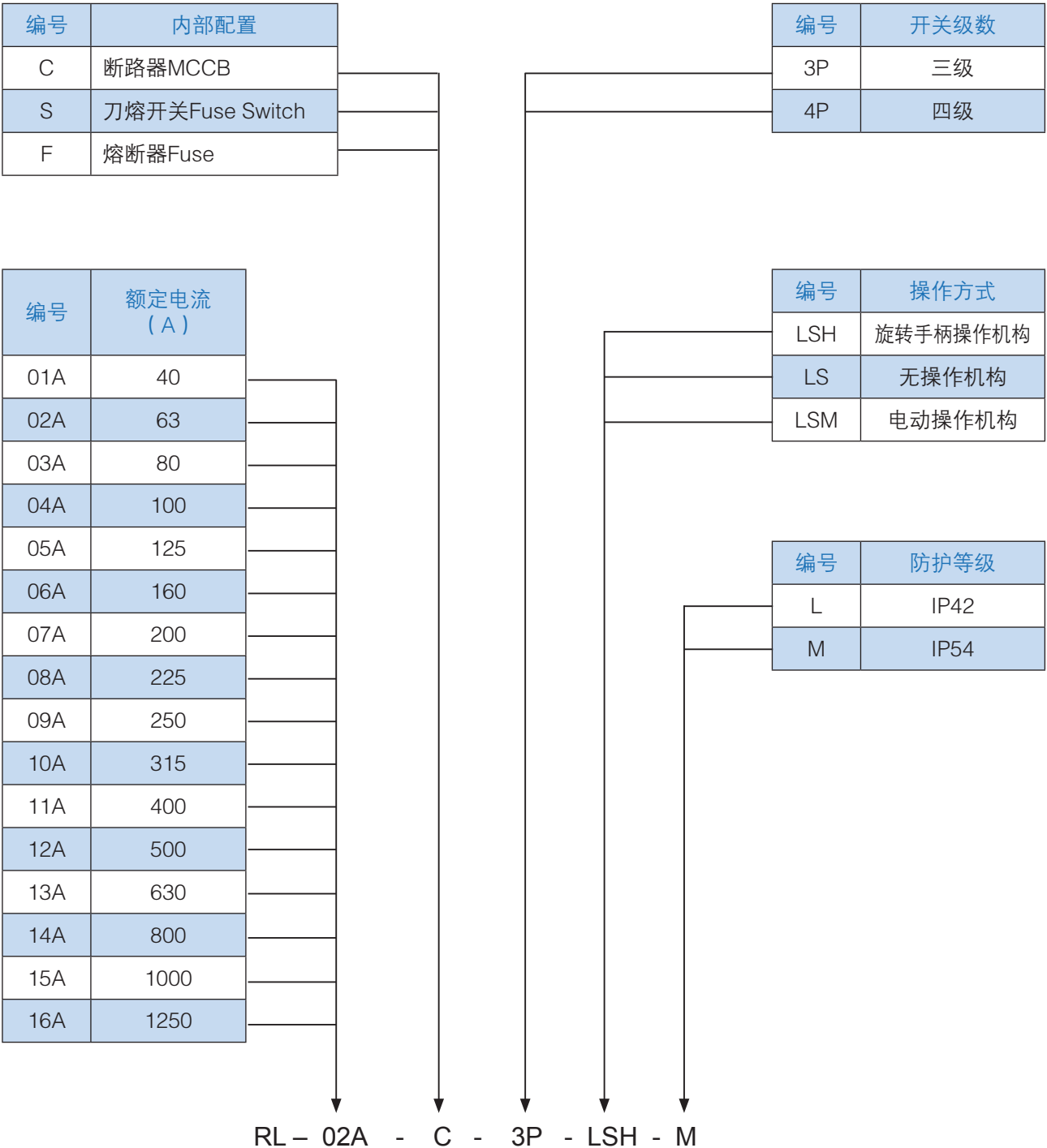

举例说明：RL-02A-C-3P-LSH-M,表示插接箱额定电流为63A，断路器保护，断路器为3级，旋转手柄操作机构，防护等级为IP54

密集型母线槽外壳 Intensive Busbar Trunking Shell

- 外壳采用加强型模制电工用铝镁合金型材组成，具有重量轻、低磁耗、无污染及美观等特征；
- 该外壳具有极好的散热性、接地性，可消除大电流母线相间的涡流现象，降低母线导体因涡流而引发的发热现象。
- 防腐蚀能力强，不锈蚀，表面经静电粉末喷涂可耐1200小时盐雾实验。
- shell with strengthened mold electrical Mg-Al alloy profile features light weight, low magnetic consumption, pollution-free and aesthetic outline and etc.;
- the housing having excellent thermal conductivity, grounding property, which can eliminate the eddy current phenomena between large current busbar phases, reducing heat generation consequently.
- Good anti-corrosion ability; the surface of the electrostatic powder coating can withstand 1,200 hours of salt spray test.

密集型母线槽导体 Intensive Busbar Trunking Conductor

- 密集型母线槽系统导体表面镀锡或镀银处理，导体整体包覆高性能绝缘聚酯薄膜（包覆两层）；
- RL为铜导体系统，RLA为铝导体系统。
- 铝导体表面镀锡前先做镀镍、镀铜处理。
- Surface of Intensive Busbar trunking Systems conductor is tinned or silver-plated, overall conductors are coated with high-performance insulation polyester films (two layers);
- RL is copper conductor system, RLA is aluminum conductor system.
- aluminum conductor surface shall be nickel, copper plated before tinned plating.

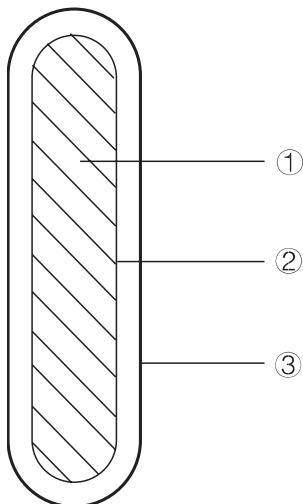

密集型母线槽导体系统

Intensive Busbar Trunking Conductors System



高性能绝缘聚酯薄膜

High-performance insulating polyester film

- ①导体：铜排(RL)、铝排(RLA)；
- ②镀层：镀锡层(RL)，镀镍层、镀铜层、镀锡层(RLA)；
- ③高性能绝缘聚酯薄膜。
- ① Conductor: copper (RL), aluminum busbar (RLA);
- ② Plating: tin layer (RL), nickel plating, copper plating layer, the tin layer (RLA);
- ③ high performance insulating polyester film.

密集型母线槽导体配置 Configuration of Intensive Busbar Trunking Conductors

IEC364标准规定配电设备的系统配置需根据整套系统配置进行选择，而且所选择的设备要充分保证整个系统的安全；

母线槽系统拥有多种导体配置系统，能适应不同工程对系统的需求。

IEC364 standard system specifies the system configuration of power distribution equipment shall be based on the configuration complete set of system configuration and the selected equipment shall fully guarantee the security of the entire system;

RL Series busbar trunking system has a variety of conductor configurations that can adapt to the requirements of different projects regarding the systems.

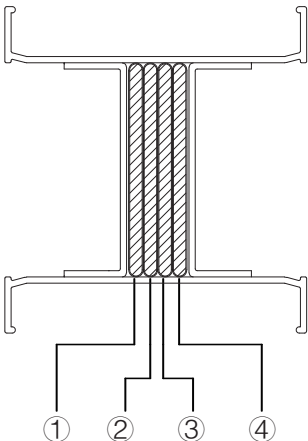
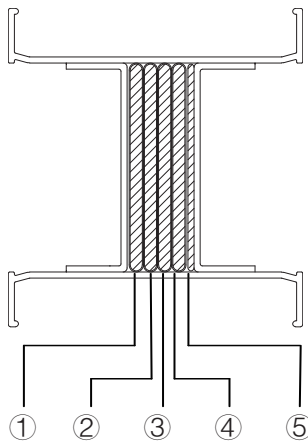
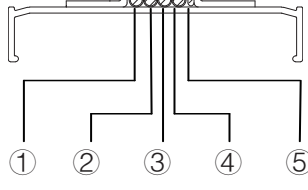
系统System	导体配置Conductor configurations					外壳Enclosure
	①	②	③	④	⑤	
	L1	L2	L3	N		外壳作PE
	L1	L2	L3	N	PE	外壳与PE相连
	L1	L2	L3	N	N	外壳作PE

外壳作PE：通过验证采用无磁的镁铝合金外壳为整体式接地导体，它的接地容量超过相线100%。当系统出现高容量的接地故障时，使用系统直接与大地相通，它具备最短的接地途径。

Housing as PE: it is validated that non-magnetic Mg-Al alloy casing is used as integral grounding conductor, and its grounding capacity exceeds 100% more than phase conductor.

When a high-capacity ground fault occurs in the system, the system is directly connected with the ground, and it is the shortest route to ground.

密集型母线槽外形尺寸 Dimensions of Intensive Busbar Trunking

外形尺寸主要取决于密集型母线槽系统的额定电流等级和导体材料，共分13个电流等级，其中10个电流等级采用单层设计，其它为双排设计。

Dimensions depends primarily on the rated current rating and conductor material of intensive busbar trunking system, and there are 13 current levels, of which 10 current levels use single-layer design, the others use double busbar design.

电流等级 (A)	高度H (mm)	
	RL	RLA
400	102	102
630	102	112
800	102	127
1000	112	157
1250	127	182
1600	157	227
2000	182	257
2500	227	307
3000	257	-
3200	307	495
4000	415	595
5000	495	-
6300	595	-

宽度均为145mm
Width is always 145mm

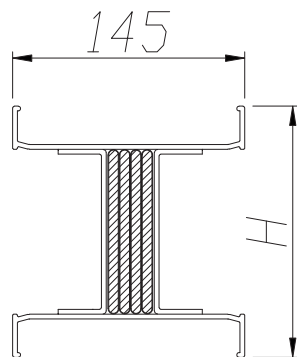

单排 Single Busbar

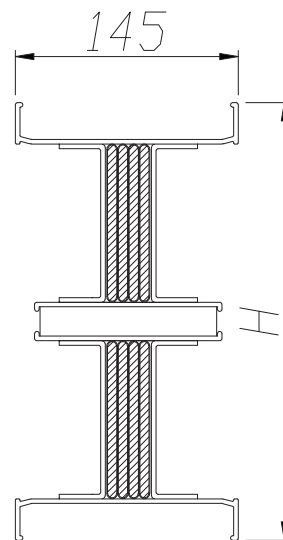

双排 Double Busbar

密集型母线槽直线段单元 Straight Intensive Busbar Trunking Units

密集型母线槽整体结构为完全密封型，最高防护等级可达IP65，可在恶劣环境下安全运行。系统选择具有大于相线100%容量的整个外壳作为接地系统，保证足够的安全性，为接地故障提供可靠的接地路径，为地线短路提供最短的路径。当发生高容量的接地故障时，可有效的接地和保护整个系统。馈电式母线槽既可以垂直安装也可以水平安装。

Overall structure of intensive busbar trunking unit is completely sealed, the highest degree of protection is up to IP65, which could safely operate in harsh environments. Selection of the housing with 100% greater grounding capacity than phase line as grounding system, ensures adequate safety, providing reliable ground path for the ground fault (the shortest path for ground short circuit). When a high-capacity ground fault occurs, effective grounding can protect the whole system. Feeder busway can be installed either vertically or horizontally.

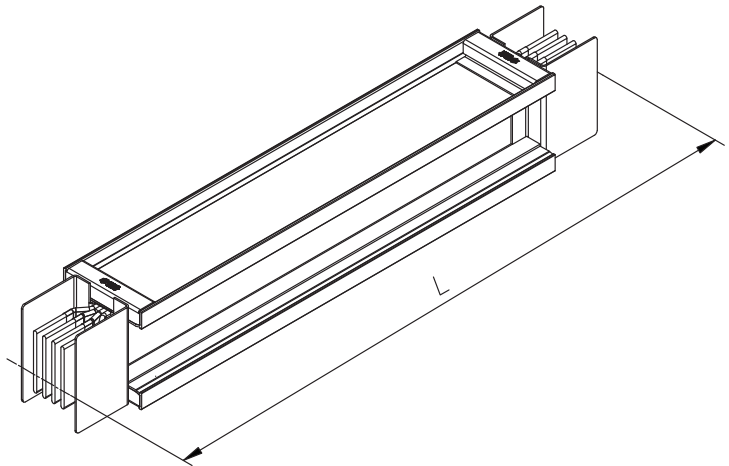

标准长度		
RL	1m	2m
	3m	4m
	6m	-
可选长度		
RL	0.5m~5.99m	

标准长度		
RLA	1m	2m
	3m	4m
	6m	-
可选长度		
RLA	0.5m~5.99m	

密集型母线槽直线段带插口单元 Straight Intensive Busbar Trunking Units with Tap-off Points

密集型母线槽既可以垂直安装也可以水平安装。插口设置灵活，双面都可以设插口。6m长标准段单侧最多可以配置9个插孔，用户可以根据具体情况预留插接口以便在设备负载更换位置或增加时使用，为客户提供安全可靠的用电环境；每个插接口均设有插口绝缘阻燃型底座和插口绝缘阻燃型盖板。

Intensive busbar trunking system with tap-off units can be mounted vertically or horizontally installed. Tap-off points configuration is flexible, both sides could be arranged with tap-off points. The standard 6m long section at one side can be configured with 9 tap-off points, the user can reserve tap-off points for displacement of the equipment or extra needs, providing customers with safe and reliable electricity application; each tap-off point has a socket insulation flame retardant base and socket insulation flame retardant cover.

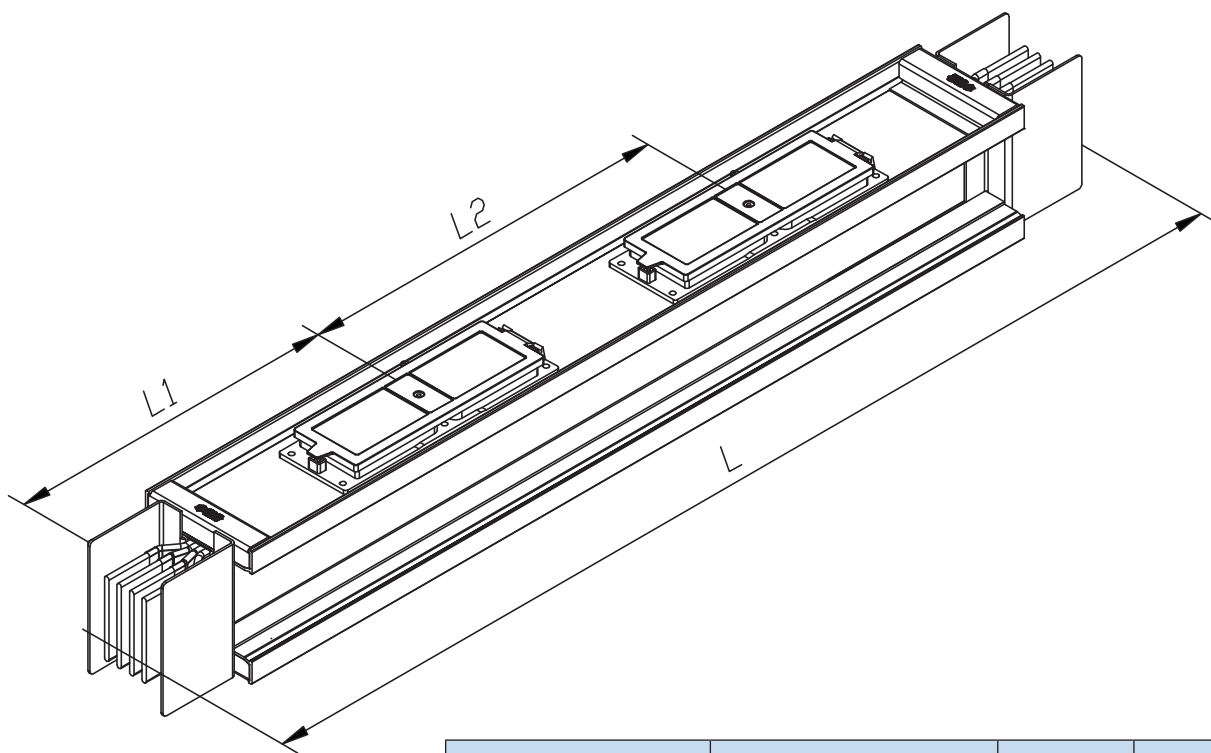

标准长度	L	L1	L2
RL	1m/2m/3m/4m/6m	600	600
可选长度			
RL	0.5m~5.99m	600	600

标准长度	L	L1	L2
RLA	1m/2m/3m/4m/6m	600	600
可选长度			
RLA	0.5m~5.99m	600	600

密集型母线槽换向单元 Intensive Busbar Trunking Angle and Branch Units

密集型母线槽提供了完整的标准弯通单元可以满足所有走向布置要求，特殊弯通单元可以根据用户要求定制。

Intensive Busway system provides complete standard elbow units which could meet all requirements of system layout, special elbow unit can be customized according to user requirements.

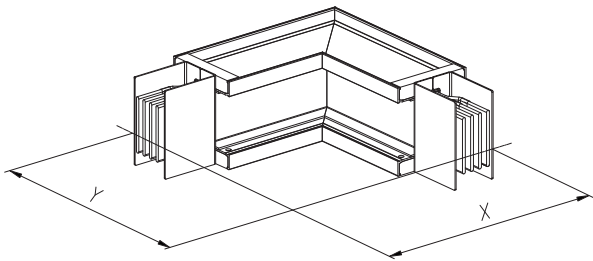

L型水平弯通 L Type Horizontal Elbow

标准长度	
RL	X/Y=0.4m
RLA	X/Y=0.4m

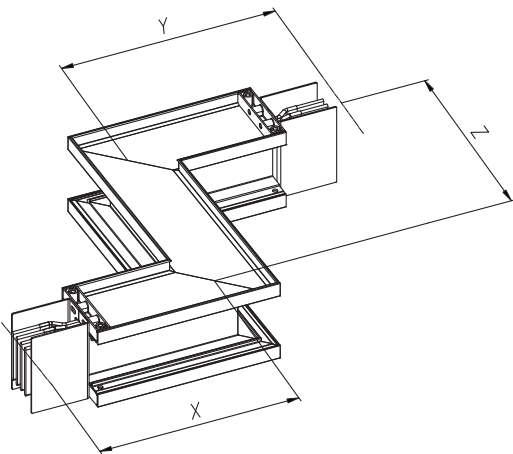

Z型水平弯通 Z Type Horizontal Elbow

标准长度	
RL	X=0.4 m Y=0.4 m Z=0.4~1.0m
RLA	X=0.4 m Y=0.4 m Z=0.4~1.0m

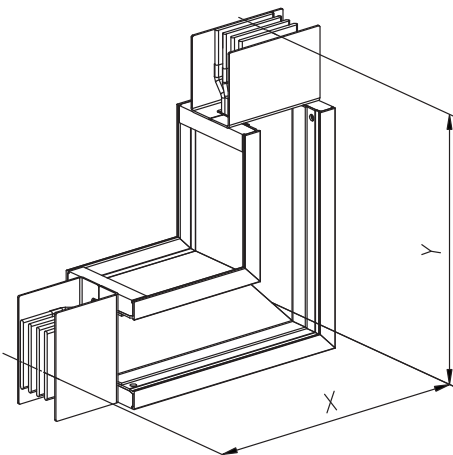

L型垂直弯通 L Type Vertical Elbow

标准长度	
RL 00R~04R	X=0.4 m Y=0.4 m
RL 05R~07R	X=0.55m Y=0.55 m
RL 08R~12R	X=0.8m Y=0.8 m
RLA 00R~07R	X=0.55 m Y=0.55 m
RLA 09R~10R	X=0.85m Y=0.85 m

密集型母线槽换向单元 Instensive Busbar Trunking Angle and Branch Units

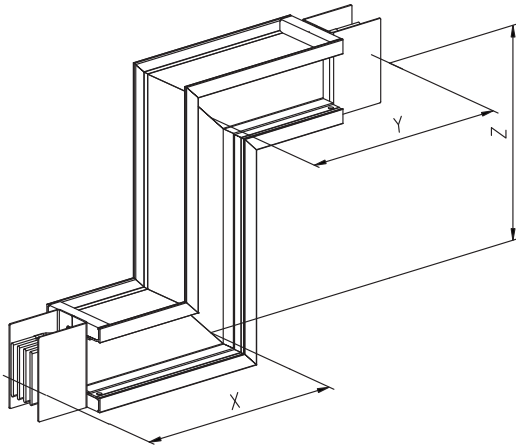

Z型垂直弯通 Z Type Vertical Elbow

标准长度	
RL 00R~04R	X=0.5 m Y=0.5 m Z=0.5~1.0m
RL 05R~07R	X=0.55m Y=0.55 m Z=0.7~1.2m
RL 08R~12R	X=0.8m Y=0.8 m Z=1.2~1.7m
RLA 00R~07R	X=0.55 m Y=0.55 m Z=0.7~1.2m
RLA 09R~10R	X=0.85m Y=0.85 m Z=1.2~1.7m

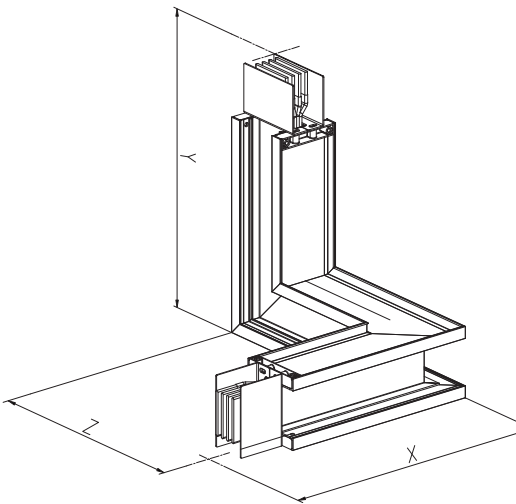

异型垂直弯通 Nonstandard Vertical Elbow

标准长度	
RL 00R~04R	X=0.5m Y=0.5 m Z=0.5m
RL 05R~07R	X=0.6m Y=0.6 m Z=0.6m
RL 08R~12R	X=0.8m Y=0.8 m Z=0.8m
RLA 00R~07R	X=0.5m Y=0.5 m Z=0.6m
RLA 09R~10R	X=0.6m Y=0.6 m Z=0.8m

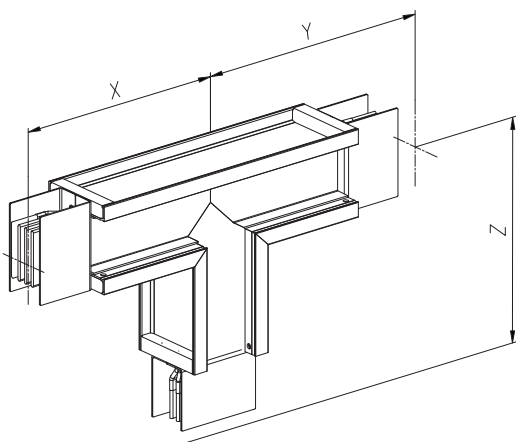

T型垂直弯通 T Type Vertical Elbow

标准长度	
RL 00R~04R	X=0.4m Y=0.4 m Z=0.5m
RL 05R~07R	X=0.5m Y=0.5 m Z=0.6m
RL 08R~12R	X=0.6m Y=0.6 m Z=0.8m
RLA 00R~07R	X=0.6m Y=0.6 m Z=0.6m
RLA 09R~10R	X=0.8m Y=0.8 m Z=0.8m

密集型母线槽始端母线单元 Intensive Busbar Trunking End Feeder

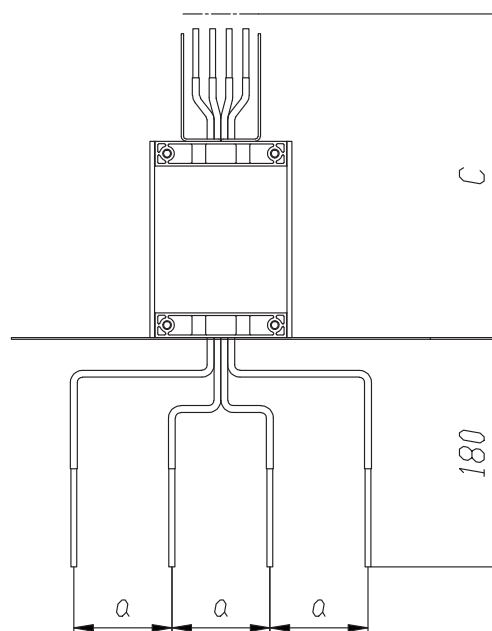
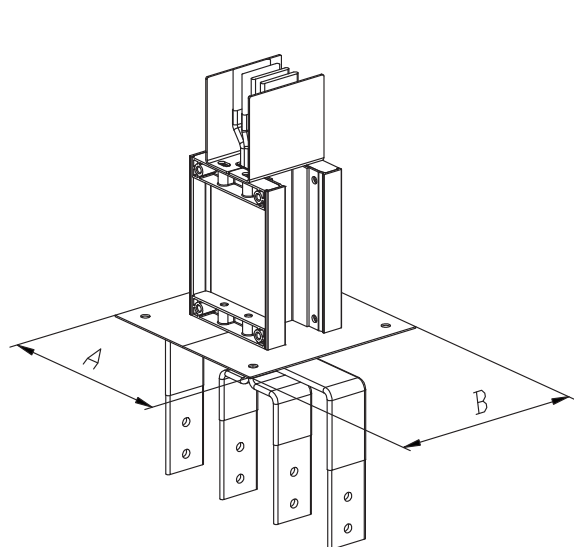

RL	A/mm	B/mm	C/mm
RL 400A	500	280	100
RL 630A	500	280	100
RL 800A	500	280	100
RL 1000A	500	280	100
RL 1250A	500	280	100
RL 1600A	500	280	100
RL 2000A	500	280	120
RL 2500A	500	320	120
RL 3000A	500	320	120
RL 3200A	500	420	120
RL 4000A	500	520	120
RL 5000A	500	600	120
RL 6300A	500	620	120

始端母线和始端箱可以与任何型号的低电压配电柜、变压器进行配套，也可根据用户需求确定始端母线的外形尺寸。

RLA	A/mm	B/mm	C/mm
RLA 400A	500	280	100
RLA 630A	500	280	100
RLA 800A	500	280	100
RLA 1000A	500	280	100
RLA 1250A	500	280	120
RLA 1600A	500	320	120
RLA 2000A	500	320	120
RLA 2500A	500	420	120
RLA 630A	500	520	120
RLA 3200A	500	600	120
RLA 4000A	500	620	120

End feeder trunking unit and the end feeder box can match any type of low voltage power distribution cabinet transformer. Also, dimensions of the end feeder trunking unit could be customized according to users' needs.

连接器单元 Connection Units

摒弃了传统的设计，使得安装速度较普通连接器快一倍。由于它不可翻转，两段母线在连接时不会发生错相，简化安装程序，更有助于安全快速的安装。

- 连接器绝缘材料采用DMC复合型高效绝缘模塑料高温模压，具有很高的抗压性、耐弧阻燃性和综合电抗性能；
- 宽沿锰钢蝶形弹簧，确保了接触面受力均匀，并防止松动；
- 双头螺栓设计，安装时仅需一把普通19#扳手拧断外部螺母即可保证安装力矩（80N•M），安装完毕后剩余的螺栓可在维修、拆装时二次利用；
- 为了补偿安装误差对连接的影响，连接器沿母线长度方向有 $\pm 7\text{mm}$ 的补偿。



Abandoning the traditional design makes installation twice as fast as ordinary connector installation. As it can not be overturned, wrong phase connection does not occur when two busbars are connected. The simplified installation process helps secure and rapid installation.

- The insulation materials of connector is efficient DMC composite insulating material, using high temperature compression molding, which has high compression resistance, arc resistance flame resistant as well as integrated reactance properties;
- Wide-brim manganese steel butterfly spring ensures the contact surface under uniform force and prevents its loosening;
- With stud design, only an ordinary 19 # wrench is need for installation to break off the external nut, which ensures the mounting torque (80N• M). The rest of bolts after installation could be reserved for repair and maintenance.
- To compensate the installation deviation, there is $\pm 7\text{mm}$ compensation at the direction along the busbar of joint.

防护等级高 High Degree of Protection

连接器各零部件之间均设计有防水措施，同时加有绝缘垫的连接盖板使得在母线连接处也有能保证较高的防护等级。

Among components of joints are designed with waterproof measures, while connection cover with extra insulator ensures higher level of protection at the busbar joints.

安全可靠的分接单元 Safe and Reliable Tap-off Units

双金属插脚结构，表面镀银处理，确保持久的接触压力和较低的接触电阻。配备了安全联锁机构，插接箱未安装到位时，无法合闸，能够有效避免插接箱带负荷插拔。防错相设计，确保插接箱插拔无误。插接箱的所有带电部件均进行了有效的电气隔离，插接箱安装时，其地线先于相线与母线接通，插接箱拆卸时，地线最后断开。

Structure of bi-metal contacts with silver plated surface ensures lasting contact pressure and low contact resistance. Equipped with safe interlocking mechanism, tap-off units can not be switched on when it is not placed properly, which effectively avoid its on-load plugging. Design of phase-dislocation proof ensures correct plugging. Effective electrical isolation is applied to all current carrying parts of tap-off units. During its installation, its grounding line will be connected before phase line's connection; while for its dismounting, grounding line will be the last line disconnected.

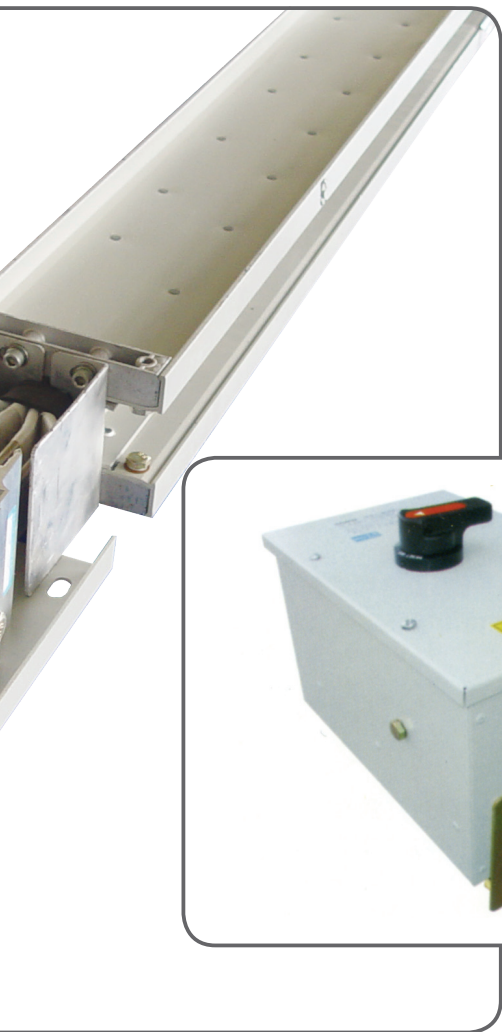

与低压配电柜连接 Connection with Low-voltage Power Distribution Cabinet

始端母线与始端箱可实现与任何型号的低压配电柜连接，始端母线在与配电柜连接时可根据用户低压配电柜的具体出线方式进行灵活设计，既可以柜顶侧出线，也可以柜顶出线，电流最高可达6300A。通常使用连接铜排连接进行转接，公司提供连接部件及现场指导安装。进线单元始端母线配有始端箱，与配电柜紧密连接，从而保证较高的防护等级。

End feeder trunking unit and end feeder box could be connected with any type of low voltage power distribution cabinet. RL series end feeder trunking unit can be designed flexibly to connect at the side of or on top of the power distribution cabinet appears flexible design approach based on specific users and low voltage distribution cabinet. Its current could be as high as 6300A. Typically connection copper busbar is used for adaption; we provide joint components and on-site installation guide. End feeder trunking unit of incoming line unit is equipped with end feeder box, which is closely connected with the power distribution cabinet, thus ensuring a higher degree of protection.

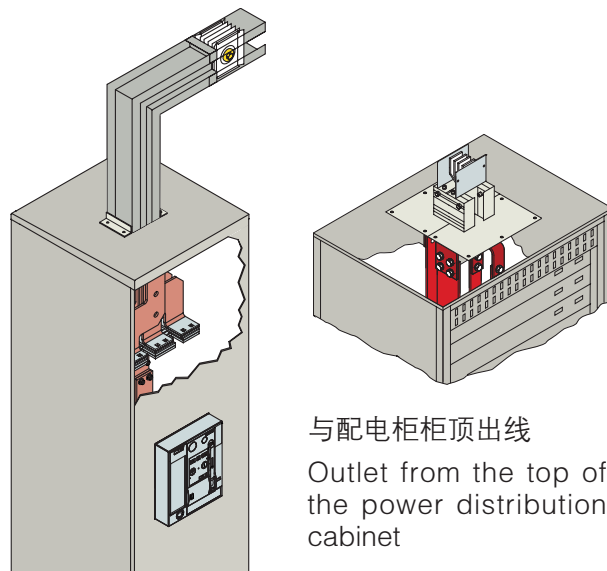

与配电柜柜顶出线

Outlet from the top of the power distribution cabinet

与配电柜柜顶侧出线

Side outlet from the top of the power distribution cabinet

与变压器连接 Connection with Transformer

始端母线与始端箱可实现与任何型号的变压器相连接，电流最高可达6300A。配有软连接，用于避免变压器运行时的微震造成的紧固件松动，从而影响到整个配电系统的运行，连接外形美观，安全可靠。根据用户变压器的具体出线方式进行灵活设计。并提供始端箱单元，保护带电部件，提高系统的防护等级和安全性能。

End feeder trunking unit and end feeder box can be connected to any type of transformer, with current up to 6300A. With flexible joints, loosening of fasteners caused by slight vibration could be avoided at the time of transformer running, consequently the operation of the entire distribution system. The connection with beautiful appearance is safe and reliable. The connection could be flexibly designed according to the specific wiring of user's transformer. End feeder box is provided to protect the current carrying parts, improving protection degree and safety performance of the system.

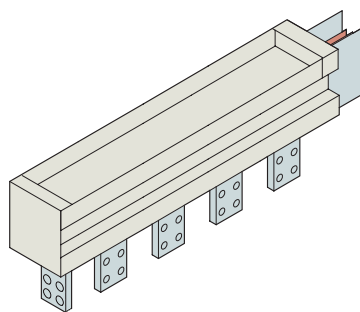

与变压器相连接

Connection with Transformer

插接箱 Tap-off Units

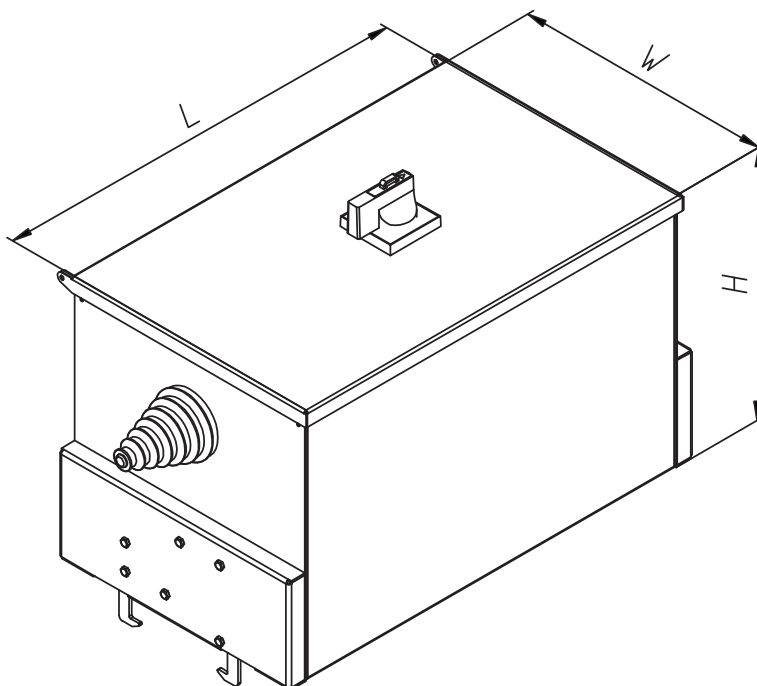

额定电流 I _e	长L(mm)	宽W(mm)	高H(mm)	备注Remarks
配断路器插接箱				
63~125	360	230	220	插接
125~250	400	250	260	
250~400	650	340	340	
630	750	340	340	栓接
800~1250	1000	450	400	
配刀熔开关插接箱				
63~125	360	230	220	插接
125~250	400	250	260	
250~400	650	340	340	
630	750	340	340	栓接
800~1250	1000	450	400	
配熔断器插接箱				
63~125	360	230	220	插接
125~250	400	250	260	
250~400	650	340	340	
630	750	340	340	栓接
800~1250	1000	450	400	



先进的密集型母线槽自动装配流水线
Intensive Busway advanced automatic assembly lines

母线装配 Busbar assembly

与传统密集型母线槽产品不同，RL和RLA系列密集型母线槽系统引进英国亨罗布自冲铆接技术，外壳整体结构采用铆钉铆接，自动化生产程度高。利用液压传动可获得较大、均匀的压力使得母线槽整体强度得到大幅度提升，并且具备良好的密封效果和防渗功能，防护等级高，电气连续性优，外形整洁美观。

Different with traditional intensive busbar products, RL and RLA Series intensive busbar system adopts British Henrob self-pierce riveting technology. The overall structure of the shell use riveting, with high degree of automated production. Use of hydraulic transmission gets larger, uniform pressure and the Busway overall strength has been greatly improved, as well as good sealing effect and impermeable abilities, high degree of protection, excellent electrical continuity, aesthetic appearance.



计算及选型 Calculation and Selection

额定电流的计算

在安排母线槽系统布局时须注意以下几点:

- ◆ 负载或配电系统的场所、数量和连接方式
- ◆ 分散系数
- ◆ 设定的短路等级

与配电柜连接须提供

- ◆ 配电柜的型号
- ◆ 进线方式(顶端、底端或背面)

安装的地理位置和条件

- ◆ 空间尺寸
- ◆ 建筑物构造(针对悬挂和安装)
- ◆ 母线槽走向
- ◆ 环境条件(温度、湿度、空气质量等)
- ◆ 系统穿过的墙面

与其他系统配套-比如与母线槽系统安装配套的部分为:

- ◆ 供电线路的平面图
- ◆ 通风管道走向的位置
- ◆ 照明系统的平面图
- ◆ 需提供插接单元的数量和具体位置
- ◆ 母线槽系统严格按照上面提到的几点进行测量, 第一步是计算额定电流。

Calculating the rated current

The following information is important for planning busbar trunking for transporting and distributing power

- ◆ Location, number and connected loads of the consumers or subdistribution systems
 - ◆ Rated diversity factor
 - ◆ Information on the short-circuit level to be expected
- Information on distribution board to be supplied

- ◆ Distribution board type
- ◆ Supply(top,bottom,rear)

Type and structure of copper busbar

- ◆ Spatial dimensions
- ◆ Building structure(for suspension and fixing)
- ◆ Transportation paths
- ◆ Ambient conditions(temperature, humidity, dirt, etc.)
- ◆ Wall cut-outs

Coordination with other system sections- for example, required coordination with the busbar trunking

- ◆ system installation plan:
- ◆ With planned power lines
- ◆ With the planned locations of ventilation duct runs
- ◆ With lighting plans
- ◆ Required number and location of the tap-off points

计算及选型 Calculation and Selection

$$I_B = \frac{P_{inst} \cdot \alpha \cdot b}{\sqrt{3} \cdot U_e \cdot \cos\phi} \cdot 10^3$$

I_B = 额定电流(A)

U_e = 额定工作电压(V)

$\cos\phi$ = 功率因数

P_{inst} = 安装功率

α = 分散系数

b = 馈电系数

$b=1$ 单面馈电

$b=0.5$ 双面馈电和中间馈电单元

The busbar trunking system is dimensioned taking into account the restrictions mentioned above. The first step is to determine the rated current.

I_B = Rated current(A)

U_e = Rated operational voltage(V)

$\cos\phi$ = power factor

P_{inst} = Installed power (KW)

α = Diversity factor

b = Feeder factor

$b=1$ with single-ended feed

$b=0.5$ with double-ended feed and centre feeder unit

主电路数	α
2与3	0.9
4与5	0.8
6至9	0.7
10及以上	0.6

除非特殊规定，一般情况下 α 都表示分散因数，这点可以参照 IEC/EN 60439-1 标准

载荷容量与环境温度的关系。

额定电流 I_e 是基于一定的环境温度而言的(24小时平均温度为 35°C ，不超过 40°C ，下面的图表就表明了载荷容量是随着环境温度的变化而变化的。

Frequently the diversity factor as per IEC/EN 60439-1(see table) can be used for unless this is ruled out by particular application.

Dependence of load-carrying capacity on the ambient temperature

The rated current I_e is based on an ambient temperature of 35°C .

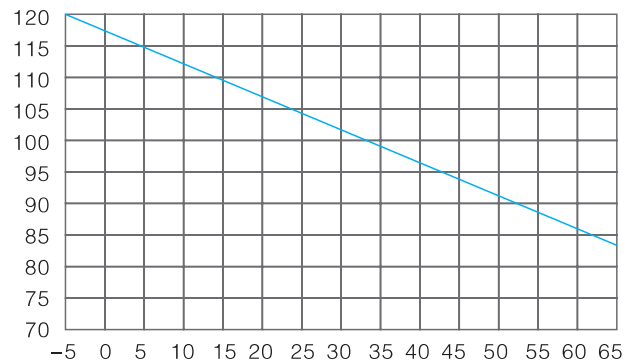

电压降的计算 Calculation of Voltage Drop

如果母线槽系统长距离输配电，就必须考虑到电压降对系统的影响，下面是电压降的具体计算公式：

$$\Delta U = a \cdot \sqrt{3} \cdot I_B \cdot I \cdot (R' \cdot \cos \phi + X' \cdot \sin \phi) \cdot 10^{-3}$$

ΔU =电压降(V)

I_B =额定电流(A)

I =系统总长度(m)

a =载荷分配系数

R' =电阻(m Ω /m)

X' =电抗(m Ω /m)

$\cos \phi$ =功率因数

For long busbar lines, it may be necessary to calculate the voltage drop.

$$\Delta U = a \cdot \sqrt{3} \cdot I_B \cdot I \cdot (R' \cdot \cos \phi + X' \cdot \sin \phi) \cdot 10^{-3}$$

ΔU =voltage drop(V)

I_B =rated current(A)

I =total length of the system(m)

a =load distribution factor

R' =resistive load(m /m)

X' =inductive load(m /m)

$\cos \phi$ =power factor

载荷分配系数须根据载荷分配的类型而定，下面的图表反映了在额定电流一定的情况下载荷分配的不同方式。

Factor a used in the equation for calculating the voltage drop is dependent on the load distribution.

载荷分布		系数A
A→ B↓	从A供电 B点插接配电	1
A→ B↓C↓D↓E↓	A点供电 B、C、D、E插接配电	0.5
B↓ A↑ C↓	从A供电 B、C点插接配电	0.25
B↓D↓A↑E↓C↓	A点供电 B、C、D、E插接配电	0.125

最小单极接地故障电流的安全断开回路阻抗决定了一极短路电流的大小，需要计算：

相线导体和保护导体

相线导体和PEN导体之间的回路阻抗

阻抗值主要取决于：

检测结果

计算结果

模拟系统

The loop impedance determines the size of the 1-pole short-circuit current. The loop impedance is calculated between the phase conductor and protective conductor
Phase conductor and PEN conductor

This value may be determined by
Measuring with measuring instruments
Calculation
Simulating the network in the network model.

技术参数表中已经详细列明了RL母线槽系统的阻抗值，因此可以根据阻抗值计算母线槽系统的回路阻抗，从而得到系统的总回路阻抗。

通过整个母线槽系统的回路阻抗，很容易估算系统的1极最小短路电流，或通过计算得到。

The Technical Data includes a listing of the impedance values of the RL busbar trunking system so that you can calculate the loop impedances of a busbar system which forms part of the total loop impedance.

With the aid of the loop impedance of the entire busbar trunking system it is easy to calculate the smallest 1-pole short-circuit current which can be expected.

$$I_{k/min} = \frac{c \cdot U_n}{3 \cdot Z_k}$$

c =电压系数0.95

U_n =相间电压

Z_k =阻抗

过载及短路保护 Overload and Short Circuit Protection

母线槽系统在运行时必须进行过载及短路保护，通常情况下熔断器或断路器都是作为保护装置而在系统中广泛使用。选择时，需考虑短路电流的强度、系统的运行功能等因素。

在实际应用中由于熔断器的灵敏度非常高，而且当电流稍微超过额定电流时，熔断器就开始熔化，但熔化的时间比较长，所以熔断器不是很适合作为过载保护装置在系统中使用

若母线槽系统的过载保护装置使用熔断器，为了保证保护装置对母线槽系统提供合适的保护，熔断器的额定电流必须要比母线槽系统的额定电流低一个等级。

如果使用断路器进行保护，其保护单元可以根据母线槽系统的额定电流进行调整，也就是说母线槽系统可以达到100%的载流量。

若决定采用熔断器和断路器作为保护装置对母线槽系统进行短路保护时，所选型号的电流不要超过母线槽系统指定的保护电流，还需考虑短路电流的强度、是否需要带限流保护装置及所选保护装置的短路开关容量是多少等因素。

如下：

$$I'' \leq I_{cc} \leq I_{cu}$$

I'' k=估计的安装位置的短路电流

I_{cc} =系统运行时的额定电流

I_{cu} =断路器的额定短路容量

Busbar trunking systems must be protected against short-circuits and overloads. Fuses and circuit-breakers are used as protective devices.

When selecting these protective devices, the strength of the expected short-circuit currents, selectivity requirements, operating and signalling functions may also be factors in your decision.

Fuses are in general less suitable as overload protection on account of their relatively high response characteristics (1.3 to 1.6 times the rated current) and their long melting time with small over-currents.

To ensure adequate protection of the busbar trunking system against overloads using a fuse, its rated current must be a step lower than the rated current of the busbar trunking system which is to be protected. This means that the busbar trunking system may not necessarily be used optimally.

If circuit-breakers are used, the thermally delayed overload release must be set to the value of the rated current of the busbar trunking system. This means that the busbar trunking system can be loaded 100%.

When you decide on your short-circuit protection via fuses and circuit breakers you must not exceed the specified short-circuit ratings of the busbar trunking systems. It will depend on the strength of the short-circuit current expected whether a current-limiting protective device is required and what short-circuit breaking capacity the protective device should have.

A tabular overview is provided below of the circuit-breakers which can provide short-circuit and overload protection (400V and 50Hz) for the corresponding trunking system.

The following applies:

$$k \leq I_{cc} \leq I_{cu}$$

k =the short-circuit current expected at the place of installation

I_{cc} = conditional rated short-circuit current of the busbar run

I_{cu} = rated short-circuit breaking capacity of the circuit breaker

密集型母线槽安装 Installation of Intensive Busbar Trunking Units

密集型母线槽系统是一种设计合理、性能优越、具有低阻抗、散热性能好、电压降低等特点，内部采用典型的三明治结构，而且全长保持密集，这种特殊结构决定了密集型母线槽系统在运行时不会受安装方式的影响，我公司将根据用户现场情况设计合理的走向。

Intensive busbar trunking system adopts the reasonable design with Superior performance, low impedance, good heat dissipation, small voltage drop, etc. The internal structure of the system is a typical sandwich configuration, and its total length maintains intensive, which determines the working Intensive Busway will not be affected by installation methods, we will design reasonable trunking layouts based on the application environment.

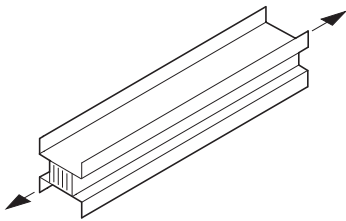

水平安装，立装

Horizontal installation: edgewise

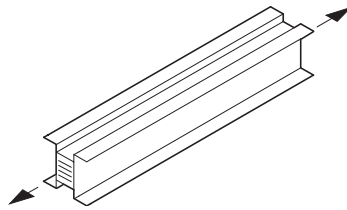

水平安装，侧装

Horizontal installation: flat

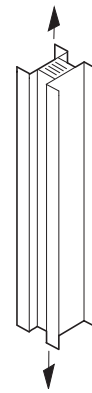

垂直安装

Vertical installation

密集型母线槽安装 Installation of Intensive Busbar Trunking Units

■ 水平安装

1. 水平沿墙安装

水平沿墙安装分立装和侧装两种方式。

■ Horizontal mounting

1. level along the wall installation

Discrete levels along the wall mounted and side-mounted installation in two ways.

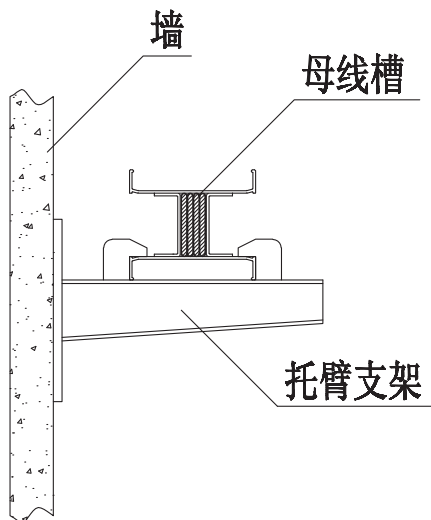

水平沿墙立装

Horizontal installation along the wall: edgewise

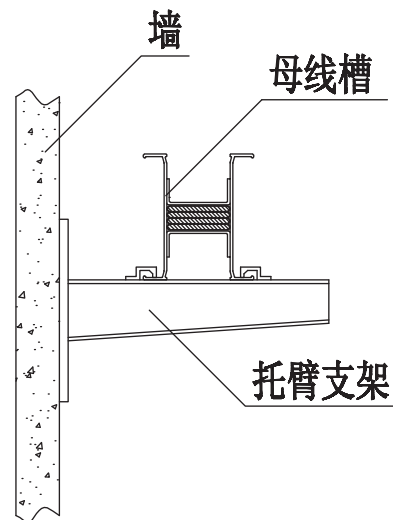

水平沿墙侧装

Horizontal installation along the wall: flat

密集型母线槽安装 Installation of Intensive Busbar Trunking Units

2. 水平吊顶安装

密集型母线槽吊顶安装时，应预先在楼板上打孔镶入钢制膨胀螺栓（也可以现场打孔，以便灵活安装）或预埋钢制件现场焊接吊装支架，如有特殊要求订货时说明。

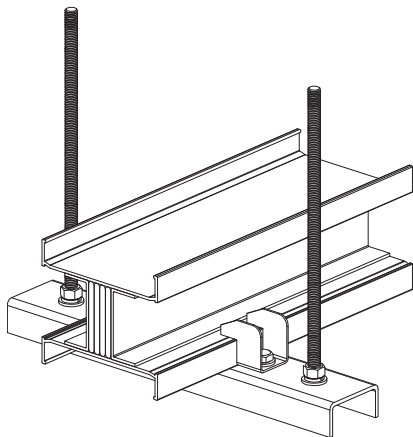

水平吊顶立装

Horizontal ceiling installation: edgewise

■ 垂直安装

垂直穿越楼层安装的母线预留尺寸见图，如为两列或两列以上母线穿越时，则应保证每两列间距 ≥ 350 。

2. horizontal ceiling installation

When Intensive Busway ceiling installation, the ceiling floor should be pre-perforated and inserted with steel expansion bolts (or drilling during installation for flexible installation), or use embedded steel parts for welding hanging bracket. For any specific requirements, please specify in the purchasing order.

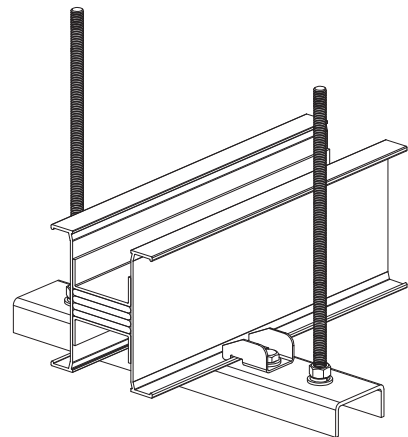

水平吊顶侧装

Horizontal ceiling installation: flat

■ Vertical installation

Vertically through the floor of the bus reserved for installation dimensions shown in Figure, if two or more busbar trunking sections run through, the clearance must be larger than 350.

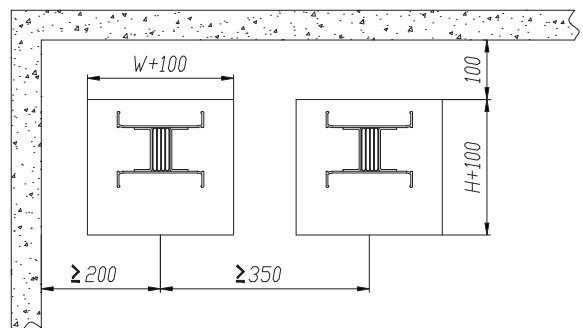

弹簧支架的主要安装方式

The main spring mounting bracket

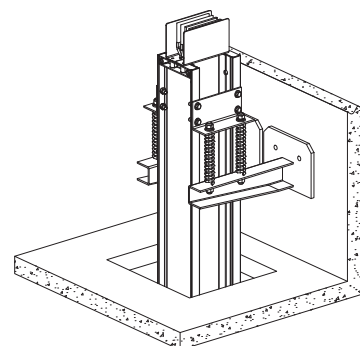
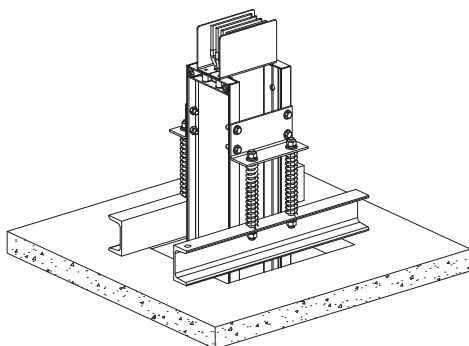

插接箱安装方式 Installation of Tap-off Units

密集型母线槽垂直安装时，对于插接箱的安装方式有着明确的规定，需要采用底线的方式，当L1导体在左侧的时候，插接箱要采用底出线的安装方式。

When Intensive busway system is installed vertically, it is clearly specified that bottom wiring is necessary for tap-off unit, when L1 conductor is on the left, the tap-off units requires bottom wiring.

密集型母线槽楼层垂直安装 Vertical Installation of Intensive Busbar Trunking Units through Floors

当密集型母线槽楼层垂直安装时需要特殊的安装附件（弹簧支架），而且如果是单套系统，每层则至少需要加装一组弹簧支架装置，如果双系统，则至少需要加装两组弹簧支架装置，弹簧支架的作用主要是为了承载母线槽自身的重量及运行时产生的线性膨胀有两种不同的规格型号可供选择，在选择时要考虑到插接箱所带来额外重量，同时对于输电母线和配电母线要有区别，针对不同的母线槽型号进行不同的选择。

When mounted vertically, Intensive Busway systems need special mounting accessories (spring bracket): for a single system, each floor at least needs to install one spring bracket; for dual systems, at least two spring bracket shall be installed. The spring brackets are primarily used to carry it's the weight of busbar trunking and its linear expansion in operation. There are two different types of products to be chosen from, and the extra weight of tap-off units should be taken into consideration when making choices. For the busbar trunking unit with and without tap-off units, the choices must be made accordingly.

	电流等级 (A)	弹性支承器数量
输电	400~2500	1
	3000~5000	2
配电	400~2500	1
	3000~5000	2

注：配电情况下每层楼至少一套插接箱单元。

- ①终端
- ②插接箱单元
- ③弹簧支架
- ④防火栅
- ⑤天花板厚度
- ⑥母线距墙要有合适的距离，建议在100mm以上
- ⑦配电柜

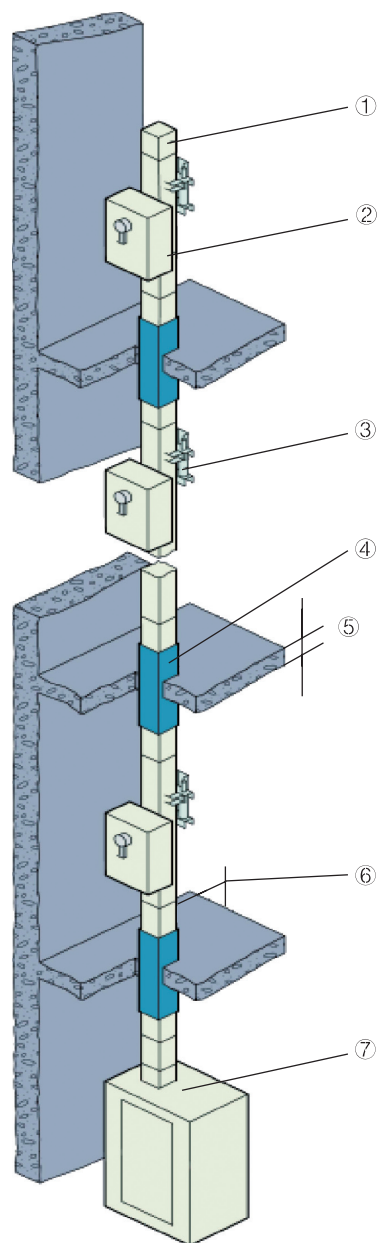

垂直安装的母线槽走向图

维修与保养 Repair and maintenance

母线槽长期运行时至少每年定期检修一次。

检查总的负载电流不得超过设计电流和主母线槽的额定电流。

母线槽检修前需对母线槽系统进行停电检查！完全切断母线槽所有电源！并用万用电表测量导体有无电压，确认母线槽系统未带电，方可例行检修。防止高电压对操作人员构成身体伤害甚至死亡的严重事故！！

母线槽运行中，应不间断查看整条系统四周是否存在渗漏、喷水、潜在的潮气源，是否存在对系统构成威胁的重物，以及对母线槽系统温升构成影响的热源；检查有无异物进入母线槽内部。检查母线槽系统零部件有无缺损、锈蚀现象，支架弹簧是否有合适的弹力，发现问题后立即更换。

母线槽长期运行时每年定期检测一次接头温升及外壳温升，应按照GB7251标准接头温升不超过70K、外壳温升不超过55K为合格。检查所有母线槽接头连接螺栓及导体接触部分是否有松动现象。防止因松动产生的阻值增高而使接头产生发热现象。检查绝缘材料是否有老化现象，导电部分是否有熔化变形现象。如发现有相间接地、绝缘击穿现象，应分段拆除并用耐压测试仪分段检查、找出故障，或重新更换母线槽、或重新进行绝缘包覆处理。检查母线槽系统的插接箱插接脚与母排接触是否良好。

定期清除母线槽系统表面积尘，确保散热良好。

母线槽系统检修完毕、重新送电前，应检查绝缘电阻并有完整的检修记录。

For the long-time running busbar trunking system, recondition at least once a year.

The total load current must not exceed the design current and main busbar rated current.

Before the maintenance of Busway system, make sure power off of the system. Cut off all power! And check with a multimeter whether voltage exists on the conductor; confirm busbar system is not charged before routine maintenance. High voltage could cause bodily injury of the operator and serious accidents even death! !

When Busway System is running, keep watching whether there exists water leakage, water spray, potential moisture sources, whether there is any heavy objects threatening the system, as well as a heat source from temperature rise of the busway system that may affect the system; check if any foreign matter inside the busbar trunking. Check whether there exists any the defects, corrosion of Busway system components, whether the bracket spring retains suitable elastic force, they should be replaced immediately, given any problems found.

Periodically test the temperature rise of busbar trunking joints and shells once a year, when the system keep long-time running. The temperature rise of the joint should not exceed 70K and that of shell should not exceed 55K as qualified in accordance with the standard GB7251. Check all connecting bolts of busbar joints trunking and the conductor contact whether any loosening phenomenon exists. Prevent heat generation from the increased resistance as a result of loosening. Check the insulation material if there is any aging problem, or any melting deformation at conductive part. If there exists phase grounding, insulation breakdown, it is necessary to remove by sub-segments and measure with voltage tester to find the fault, or to replace the busbar trunking units, or to redo the coating treatment for insulation. Check if the tap-off units is in good contact with busbars.

Periodically clear dust on the surface of busway system and ensure good heat dissipation.

After the maintenance of busway system and before power on, check the insulation resistance and record the maintenance details.

资质文件 Certificates



资质文件 Certificates

CCC 中国国家强制性产品认证证书

证书编号: 2013010301651448

委托人名称、地址
江苏润圣电气有限公司
扬州市泰柳北路

生产者(制造商)名称、地址
江苏润圣电气有限公司
扬州市泰柳北路

生产企业名称、地址
江苏润圣电气有限公司
扬州市泰柳北路

产品名称和系列、规格、型号
密集型母线槽(母线槽)

RL 母线干线单元:In=800A~400A, Icw=30kA;分接单元:In=400A~63A, Icw=30kA;Ue=400V, Ui=690V;50Hz;IP65(不带分接单元), IP54(带分接单元)

产品标准和技术要求
GB 7251.2-2006

上述产品符合强制性产品认证实施规则 CNCA-01C-010:2013的要求, 特发此证。

发证日期: 2013年10月24日 有效期至: 2018年10月24日

证书有效期内本证书的有效性依据发证机构的定期监督获得保持。
本证书的相关信息可通过国家认监委网站www.cnca.gov.cn查询

 主任: 
中国质量认证中心
中国·北京·南四环西路188号9区 100070
http://www.cqc.com.cn

Q 0828729

CCC 中国国家强制性产品认证证书

证书编号: 2013010301651444

委托人名称、地址
江苏润圣电气有限公司
扬州市泰柳北路

生产者(制造商)名称、地址
江苏润圣电气有限公司
扬州市泰柳北路

生产企业名称、地址
江苏润圣电气有限公司
扬州市泰柳北路

产品名称和系列、规格、型号
密集型母线槽(母线槽)

RL 母线干线单元:In=1250A~1000A, Icw=50kA;分接单元:In=630A~63A, Icw=30kA;Ue=400V, Ui=690V;50Hz;IP65(不带分接单元), IP54(带分接单元)

产品标准和技术要求
GB 7251.2-2006

上述产品符合强制性产品认证实施规则 CNCA-01C-010:2013的要求, 特发此证。

发证日期: 2013年10月24日 有效期至: 2018年10月24日

证书有效期内本证书的有效性依据发证机构的定期监督获得保持。
本证书的相关信息可通过国家认监委网站www.cnca.gov.cn查询

 主任: 
中国质量认证中心
中国·北京·南四环西路188号9区 100070
http://www.cqc.com.cn

Q 0828738

CCC 中国国家强制性产品认证证书

证书编号: 2013010301651440

委托人名称、地址
江苏润圣电气有限公司
扬州市泰柳北路

生产者(制造商)名称、地址
江苏润圣电气有限公司
扬州市泰柳北路

生产企业名称、地址
江苏润圣电气有限公司
扬州市泰柳北路

产品名称和系列、规格、型号
密集型母线槽(母线槽)

RL 母线干线单元:In=4000A~1600A, Icw=80kA;分接单元:In=630A~63A, Icw=30kA;Ue=400V, Ui=690V;50Hz;IP65(不带分接单元), IP54(带分接单元)

产品标准和技术要求
GB 7251.2-2006

上述产品符合强制性产品认证实施规则 CNCA-01C-010:2013的要求, 特发此证。

发证日期: 2013年10月24日 有效期至: 2018年10月24日

证书有效期内本证书的有效性依据发证机构的定期监督获得保持。
本证书的相关信息可通过国家认监委网站www.cnca.gov.cn查询

 主任: 
中国质量认证中心
中国·北京·南四环西路188号9区 100070
http://www.cqc.com.cn

Q 0828737

CCC 中国国家强制性产品认证证书

证书编号: 2013010301651447

委托人名称、地址
江苏润圣电气有限公司
扬州市泰柳北路

生产者(制造商)名称、地址
江苏润圣电气有限公司
扬州市泰柳北路

生产企业名称、地址
江苏润圣电气有限公司
扬州市泰柳北路

产品名称和系列、规格、型号
密集型母线槽(母线槽)

RL 母线干线单元:In=6300A~4000A, Icw=100kA;Ue=1000V, Ui=1000V; 50Hz; IP65

产品标准和技术要求
GB 7251.2-2006

上述产品符合强制性产品认证实施规则 CNCA-01C-010:2013的要求, 特发此证。

发证日期: 2013年10月24日 有效期至: 2018年10月24日

证书有效期内本证书的有效性依据发证机构的定期监督获得保持。
本证书的相关信息可通过国家认监委网站www.cnca.gov.cn查询

 主任: 
中国质量认证中心
中国·北京·南四环西路188号9区 100070
http://www.cqc.com.cn

Q 0828736

资质文件 Certificates



用户使用报告

由江苏润圣电气有限公司提供的母线槽产品在我公司太白路通信大厦干线系统、变电所自 1998 年通电运行情况正常；在红星路邮电大楼变电所中使用自 2004 年 12 月通电以来，运行情况正常。

济宁网通公司
2008 年 3 月 6 日



用户使用报告

山推工程机械股份有限公司在 2009 年 10 月履带底盘项目、2010 年 6 月履带第二工厂项目通过招标采购确定江苏润圣电气有限公司 CCX-T 密集型铜母线槽为中标单位(规格 630A~3200A,数量 1021 米,插接箱 195 台)从供货到安装调试通电运行至今已壹年多时间,带负荷运行正常。在安装过程中涉及到二次测量的部分,测量、供货及时,希望以后继续参与我们公司的物资采购招标。

山推工程机械股份有限公司
履带底盘分公司
2012 年 3 月 26 日



产品运行情况报告

西门子工厂自动化工程有限公司于 2009 年 10 月采购江苏润圣电气有限公司 CCX-T 型密集型铜母线槽，电流 1250A~2500A,数量约 200 米及配套附件，使用项目：广州轨道交通二/八号线配电室柜间联络，通电运行至今已二年时间，运行正常。

西门子工厂自动化工程有限公司

2012 年 5 月 7 日



用户使用报告

由省公司中标单位江苏润圣电气有限公司配送和安装的小区配套槽型母线及配件供货及时，性能稳定，服务周到，运行正常。配套项目（阳光水岸 141 米，金阳花园 846 米，百联华府 320 米，金山世纪花园 2235 米，江泉国际 737 米，颐龙恒泰 733 米，外滩香格里拉 280 米）





- | | |
|--------------------|---------------------|
| 西门子工厂自动化工程有限公司 | 山东电力二公司 |
| 同方环境股份有限公司 | 山东山推工程机械构件有限公司 |
| 北京博世力士乐 | 山东山推欧亚陀机械有限公司 |
| 江苏沙钢集团淮钢特钢有限公司 | 中国移动通信集团山东有限公司济宁分公司 |
| 苏州钢铁股份有限公司 | 山推股份有限公司履带底盘分公司 |
| 常熟华冶薄板有限公司 | 国网山东省电力公司物资公司 |
| 苏州天贸建材有限公司 | 国网山东省电力公司济南供电公司 |
| 道康宁（张家港）有限公司 | 国网山东省电力公司济宁供电公司 |
| 江苏淮澳钢铁有限公司 | 国网山东省电力公司淄博供电公司 |
| 无锡村田电子有限公司 | 国网山东省电力公司枣庄供电公司 |
| 中国联通淮北分公司 | 国网山东省电力公司莱芜供电公司 |
| 格力电工（马鞍山）有限公司 | 国网山东省电力公司潍坊供电公司 |
| 淮北新中原置业有限责任公司 | 国网山东省电力公司日照供电公司 |
| 青岛城市建设集团股份有限公司 | 国网山东省电力公司东营供电公司 |
| 青岛东碧山推机械有限公司 | 国网山东省电力公司临沂供电公司 |
| 山东新德蓝木业热电厂 | 国网山东省电力公司聊城供电公司 |
| 山东省千佛山医院 | 国网山东省电力公司德州供电公司 |
| 山堆国际产业园10KV变电所 | 国网山东省电力公司烟台供电公司 |
| 济宁附属医院门诊医技楼 | 国网山东邹城市供电公司 |
| 山东济宁圣地电业集团有限公司 | 济宁市第一中学 |
| 山推工程机械股份有限公司 | 济宁圣润电力安装有限公司 |
| 山东新华制药股份有限公司 | 烟台东源电力电气设备有限责任公司 |
| 中国网通（集团）有限公司济宁市分公司 | 国网山东嘉祥县供电公司 |
| 中国工商银行济宁分行 | 临沂超越电力建设有限公司 |
| 中国人寿保险股份有限公司济宁分公司 | 日照输变电工程公司 |
| 胜代机械（山东）有限公司 | 山西运城机场 |
| 山重建机（济宁）有限公司 | 山西京玉发电有限责任公司 |
| 山推铸钢有限公司 | 山西大唐平旺热电有限公司 |
| 山东兴唐房地产开发有限公司 | 山推抚起机械有限公司 |
| 德州工业设备安装有限公司 | 大唐多伦电厂 |
| 德州邮政局 | 广东大鹏液化天然气有限公司 |
| 日照电信局 | 广州地铁 |
| 济南建工总承包集团公司 | 云南曲靖多晶硅 |
| 济宁国税局 | 冀东油田 |

订货须知 Ordering Information

尊敬的用户：

非常荣幸，您能够耐心地读完我们的产品说明书，这已为我们相互了解奠定了初步的基础。真诚希望能给我们一次服务机会，我们将十分高兴地为您提供热情周到的服务。

欢迎您来公司、来函垂询，并期待着您的光临。

衷心祈盼您能选用润圣品牌系列母线槽产品，对您的一片厚爱我们将深深的感谢

当您决定选用我公司产品的时候，真诚地忠告您注意如下事项：

1. 订货前说明所需产品的型号、规格（容量）、数量及交货期；
2. 订货时应提供的资料
 - A. 主接线图、详细尺寸的走向布置图（一般由我厂人员现场测量）；
 - B. 工程平面布置图，接口设备的详细定位尺寸图；
 - C. 断面布置图；
 - D. 有关土建资料图样。
3. 若用户对产品有特殊要求，可在订货时与本公司协商，公司可按用户需要进行非标设计。

Dear Customer:

It is honored, that you patiently read our product brochure, which has laid the foundation for our initial mutual understanding. Sincerely we hope for the chance to serve, and we are ready to provide you with good service.

Welcome to call or mail us for further information, and look forward to your visit.

Sincerely hope that you can choose RunSheng Series Busbar Trunking System, and we will be deeply grateful for your choice.

When you decide to use our products, please pay attention to the following matters:

- 1 Before ordering, please specify the product model, specifications (capacity), quantity and delivery date;
- 2 When ordering, please provide the following info
 - A. Main wiring diagram, layout with detailed dimensions(usually our technical personnel will measure on-site);
 - B. Project floor plan, detailed dimension drawings for locating the joint units;
 - C. Sectional layout;
 - D. Related civil engineering drawings.
- 3 If the users have special products requirements, please consult with us at the time of ordering, we will arrange non-standard design according to user needs.

江苏润圣电气有限公司

Jiangsu Runsheng Electric Co., Ltd.

地址：江苏扬中市春柳北路

电话：86-511-88334128 88362177

传真：86-511-88327177

邮编：212200

Http://www.run-sheng.cn

E-mail:runsheng@188.com